

High Efficiency Low Emissions: The first way forward for clean coal technology

**Dr Andrew Minchener OBE
General Manager
IEA Clean Coal Centre**

IEA Clean Coal Centre mission statement

The IEA CCC will disseminate to a wide community objective analysis and information on the efficient, low emissions use of coal worldwide according to a programme agreed by the Membership: In order to achieve this objective, the focus of the IEA CCC activities comprises three broad categories:

- Towards zero emissions – including carbon abatement, emissions and effects, pollution control technology, residues.
- Coal utilisation and analysis – including coal properties, fuel handling, power generation technologies, coal conversion technologies, and industrial uses of coal.
- Economics and markets – including supply, transport and markets development, country studies, capital and operating cost reviews of current and new build technologies, including comparisons with non-coal options.

Services will be delivered through direct advice, review reports, workshops and conferences, facilitation of R&D, provision of networks and web based instruments.

Membership status of the IEA Clean Coal Centre at September 2014



Scope of the presentation

- Drivers for technology advancement
- Historical improvements in coal power generation technology
- Getting larger and introducing higher efficiency steam cycles
- HELE concept both for CO₂ and non-GHG emissions mitigation
- Current examples of HELE coal power plant
- Advanced HELE developments
- Scope to maximise HELE plants in major coal using economies
- Future work for IEACCC

Coal and sustainability

Coal can ensure energy security and economic competitiveness. There are environmental challenges but technologies are available to deal with these.

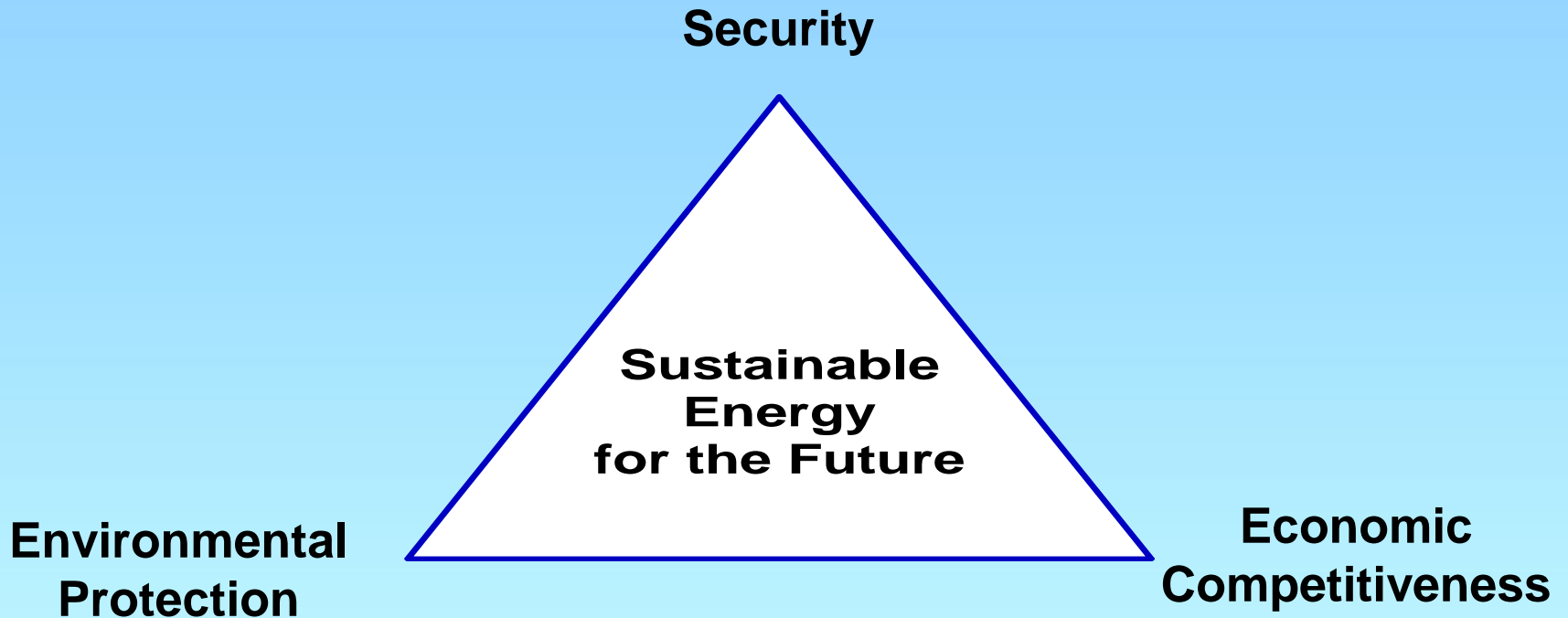

Role of clean coal technology

High efficiency low emissions technologies are critical to maintain coal based energy security and as a precursor to the longer term deployment of CCS

Essential to assist developing countries in making this choice as part of their efforts to escape from poverty through access to reliable sources of power

Lending criteria by multi-lateral donors not overly helpful

Historical improvements to power cycle efficiencies

Electricity Produced per tonne of Coal (kWh/t)

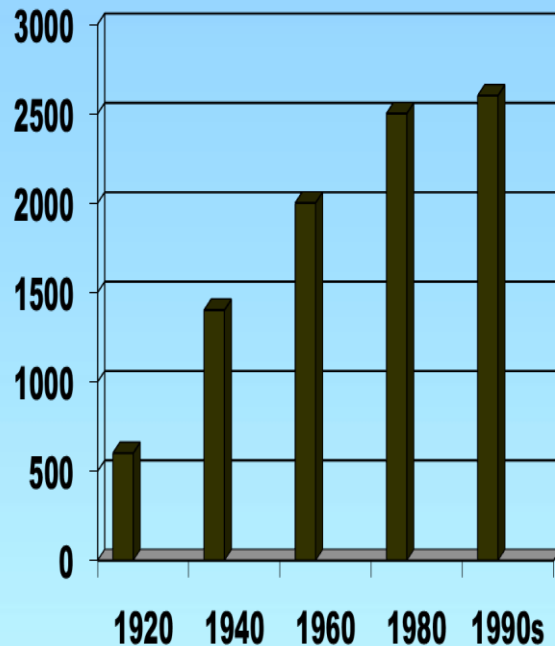

- **Economies of scale leading to larger units**
- **Higher temperature steam cycles**
- **Better integrated operating procedures**

Recent plant state of the art conditions

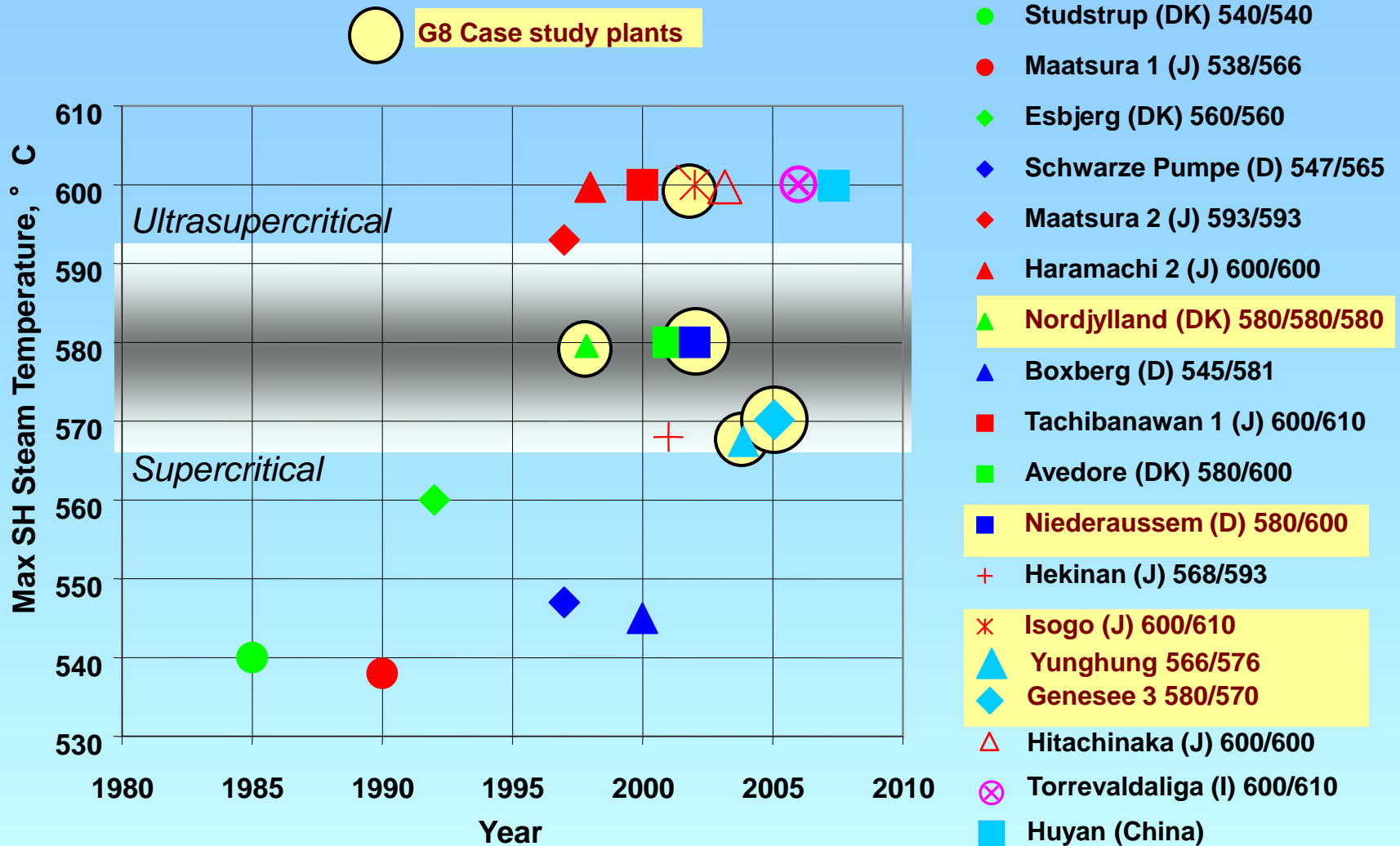

Application of sc and usc steam cycles



HELE Technologies

Focus on technologies to reduce both GHG and non-GHG (NO_x, SO₂, PM) emissions.

Technologies for cleaner coal generation

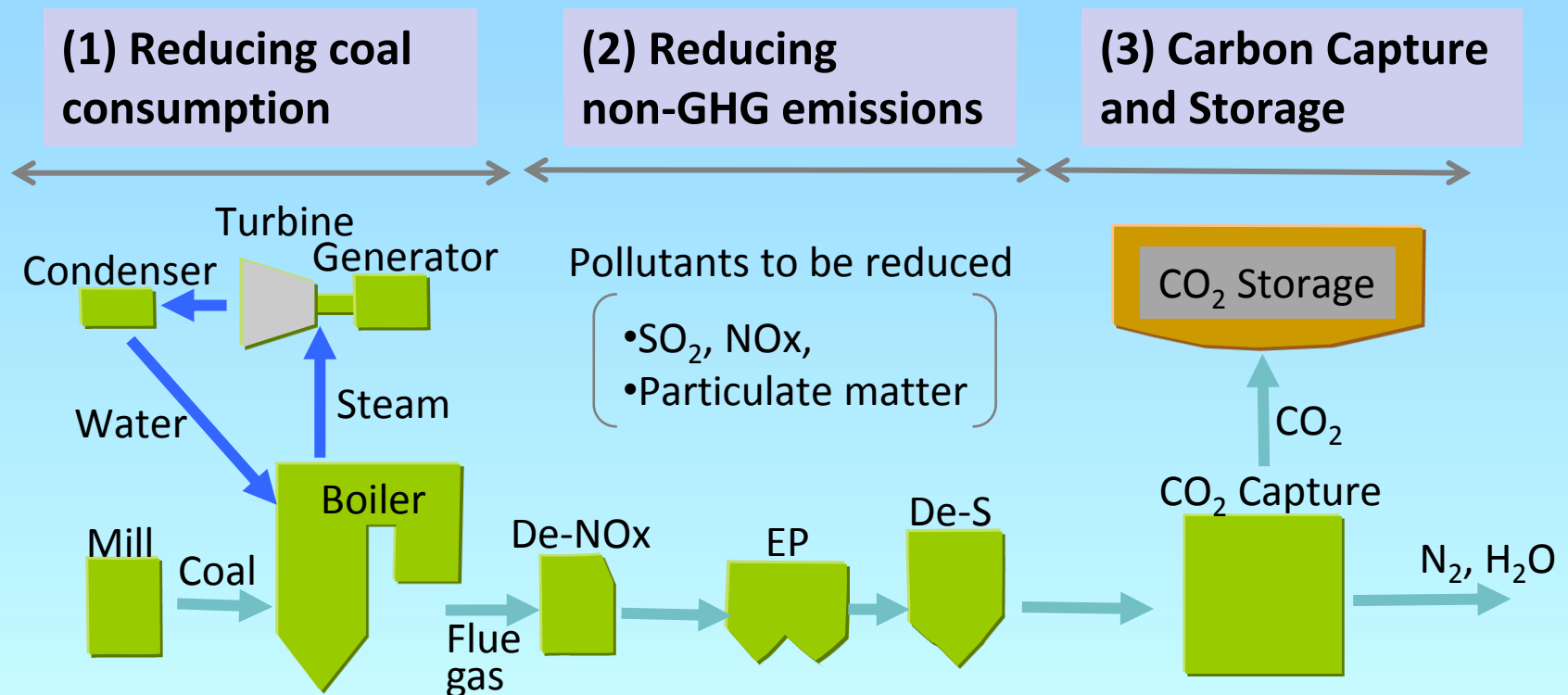

Waigaoqiao No. 3 power plant in Shanghai is one of the cleanest in the world

Seeing is believing



Coal fired power plant layout showing ESP, FGD and SCR system locations

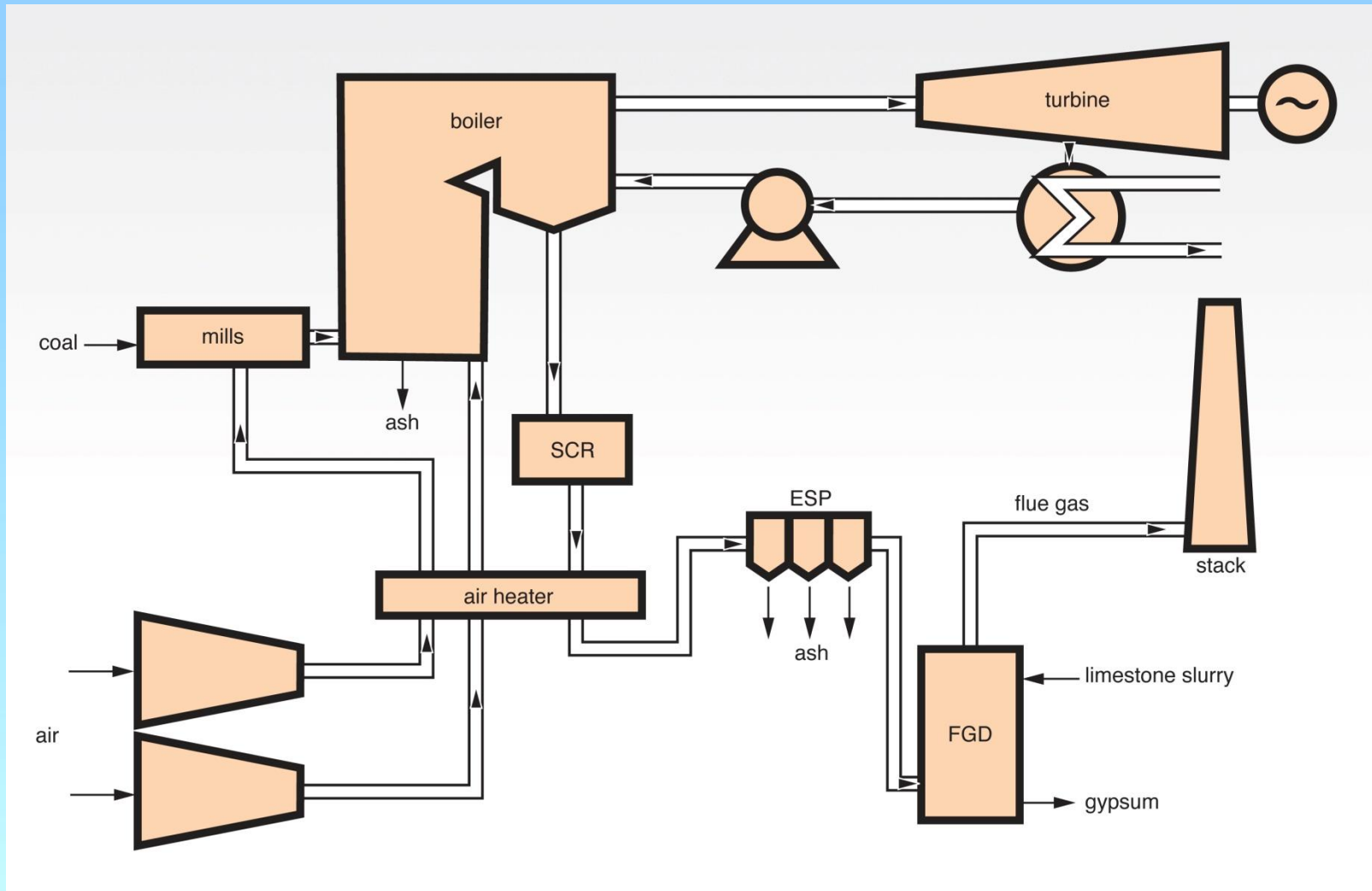

Waigaoqiao no. 3 power plant

Emissions (mg/m³)

Dust:	11.63
SO ₂ :	17.71
NO _x :	27.25

Year	2008	2009	2010	2011	2012
Net efficiency (%)	42.73	43.53	43.97	44.50	44.40
Specific coal consumption (gce/kWh)	287.4	282.2	279.4	276.0	276.1
Annual load rate (%)	75	75	74	81	77

Need to limit capital costs as well as increase steam cycle efficiency

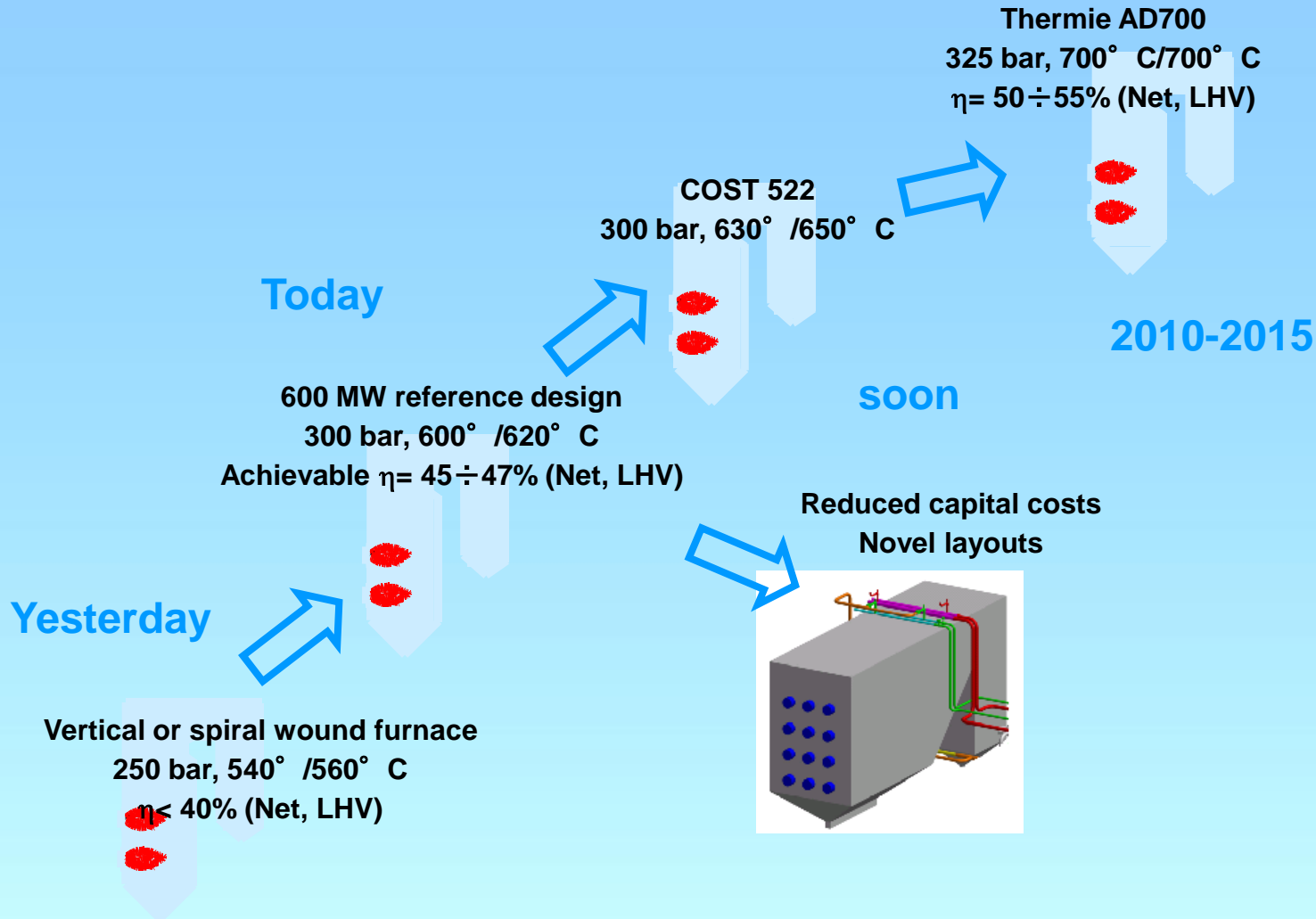

Towards $\geq 50\%$ cycle efficiency with advanced USC technology

National programme	Steam temperature	Efficiency (LHV, net)	Programme start date	Demonstration plant operational by (size)	Also includes:
EU	700°C	>50%	1998	2021 (500 MWe)	Coatings, biomass co-firing, cycling
USA	760°C	45-47% (HHV, net)	2000	2021 (600 MWe)	Oxyfuel, coatings, high sulphur coal
Japan	700°C	>50%	2008	2021 (600 MW)	Biomass co-firing
China	700°C	46-50%	2011	2021 (660 MWe)	-
India	700°C	>50%	2011	2017 (800 MWe)	-

Metals used in boiler and turbine hot spots:

- **Steels well proven in USC at 600°C**
- **Nickel based alloys proving capable in A-USC at 700°C**



Impact of efficiency improvement on CO₂ abatement

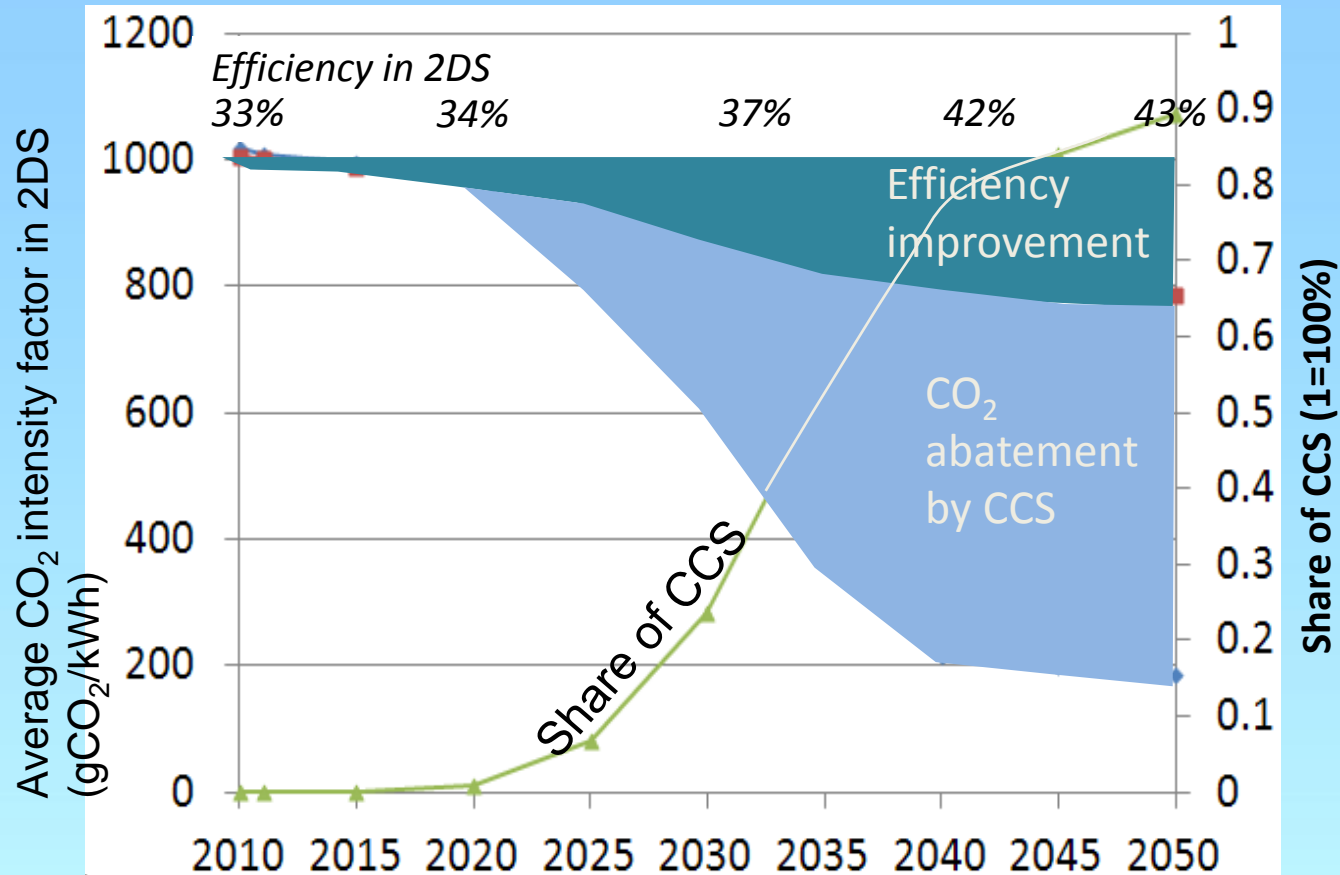

Raising efficiency significantly reduces the CO₂/kWh emitted (source: IEA HELE Roadmap, Dec 2012)

CO₂ emissions reduction by key coal utilisation technologies

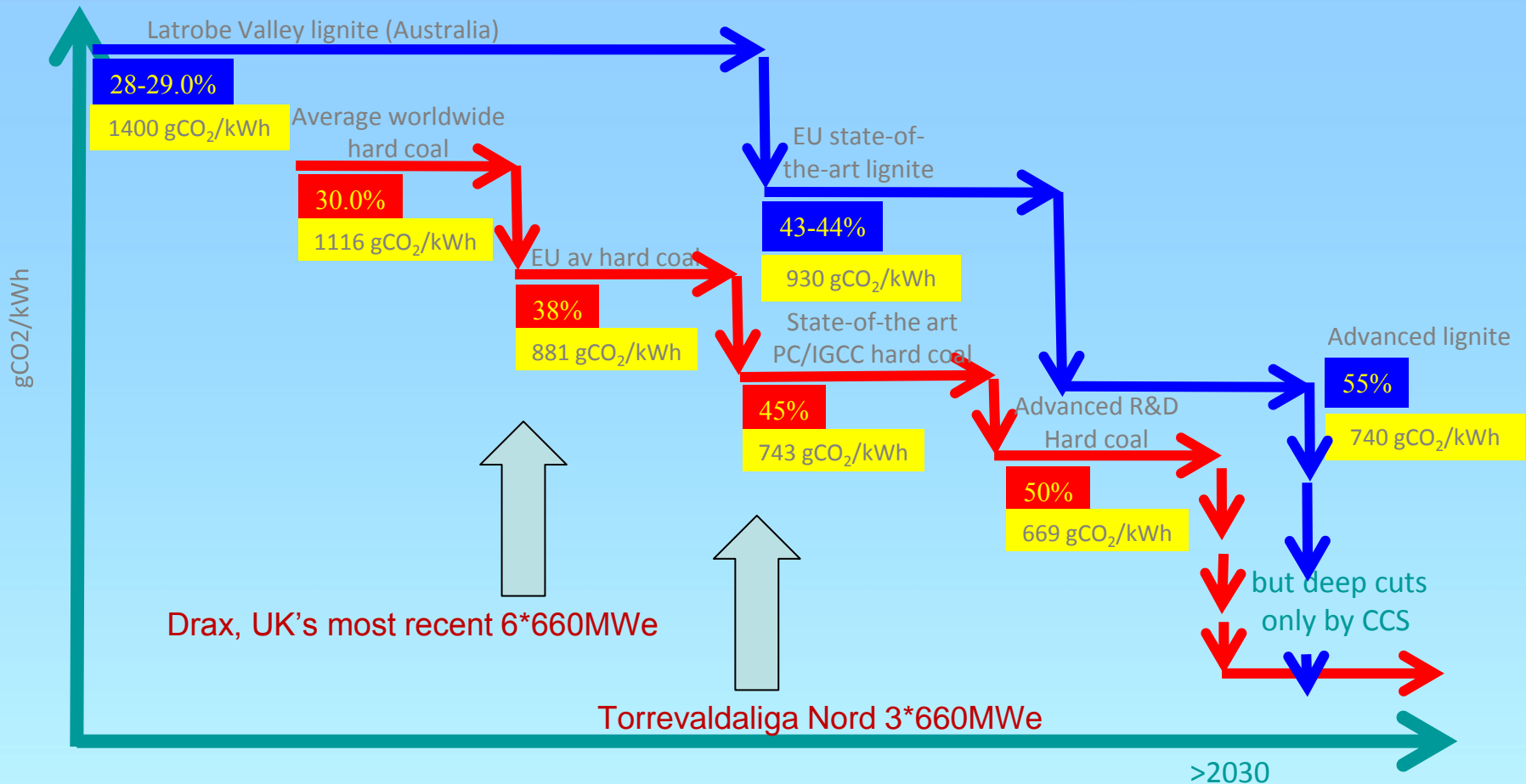

Data for hard coal-fired power plants from VGB 2007; data for lignite plants from C Henderson, IEA Clean Coal Centre; efficiencies are LHV_{net}

Energy Efficiency makes big change but deep cuts of CO₂ emission can be done only by Carbon Capture and Storage (CCS)

IEACCC HELE assessment study

- **Country specific study on the prospects for implementing High Efficiency Low Emissions (HELE) technologies**
- **Impact of HELE implementation on emissions of CO₂**
- **Look at Australia, China, Germany, India, Japan, Poland, Russia, S Africa, S Korea, USA**
- **Determine outline costs of deployment, where possible**
- **Identification of significant trends**

HELE upgrade path through phased plant retirement

Base Case

Existing coal fleet with additional USC to meet demand (if required)

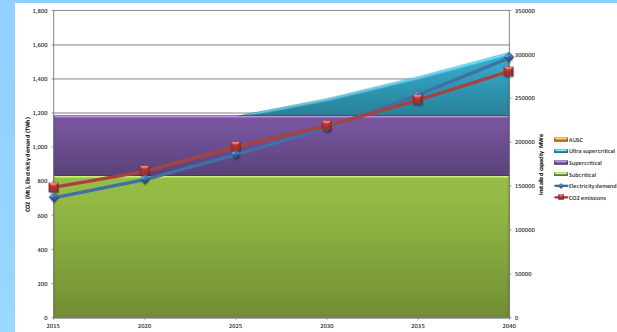

50 year retirement scenario

Review in 2020, 2030 and 2040. Retire capacity over 50 years old and replace with USC

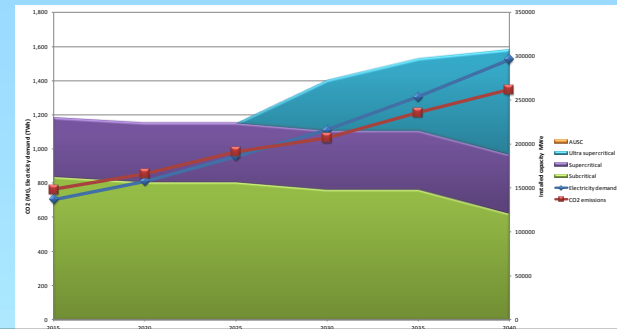

25 year retirement scenario

Review in 2020, 2030 and 2040. Retire capacity over 25 years old and replace with USC in 2020, AUSC in 2030 and 2040

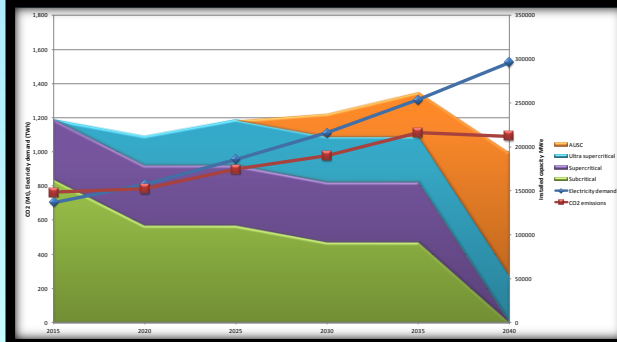

China – 25 year retirement scenario 2015 - 2040

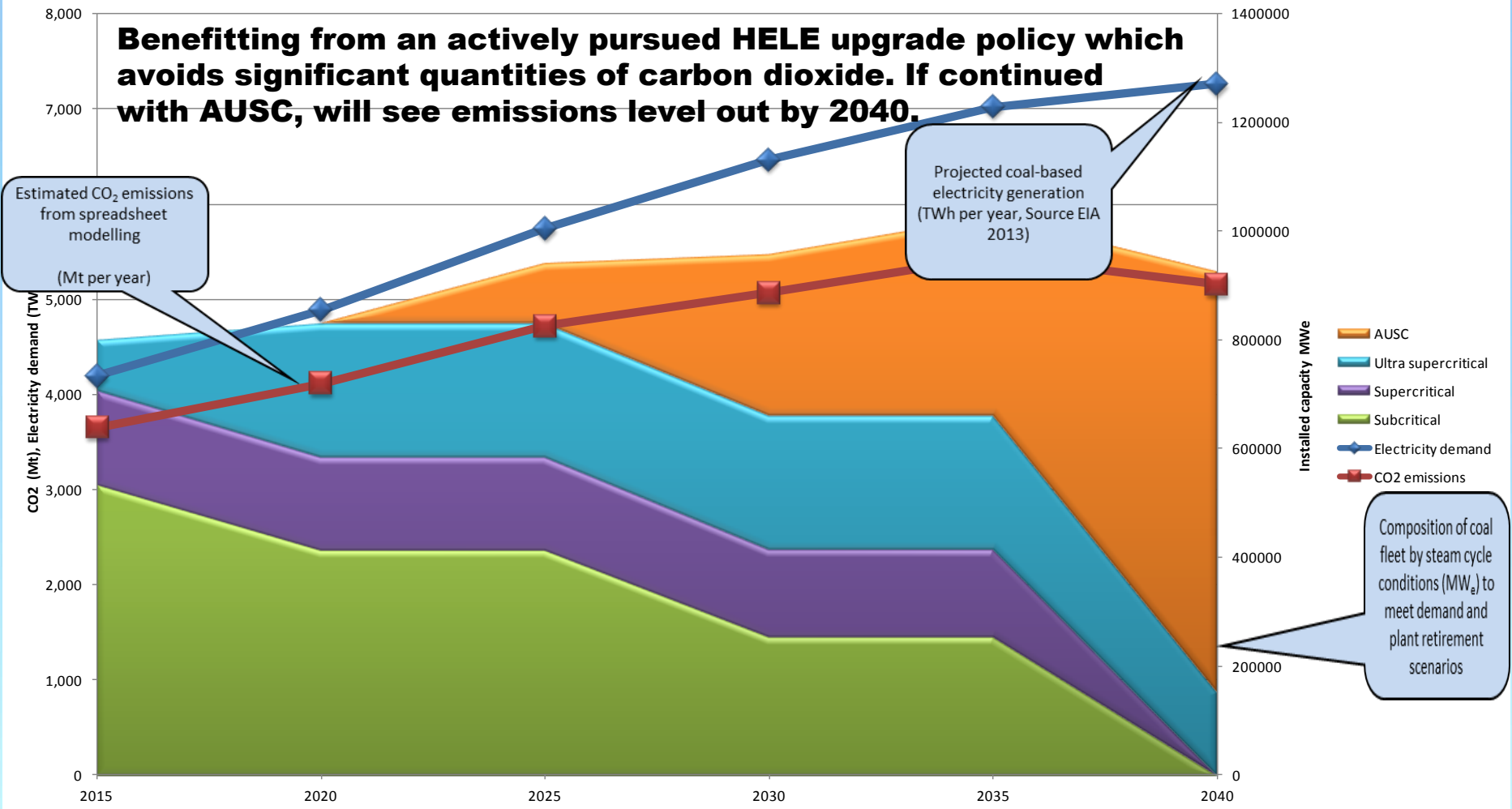

India – 25 year retirement scenario 2015 – 2040

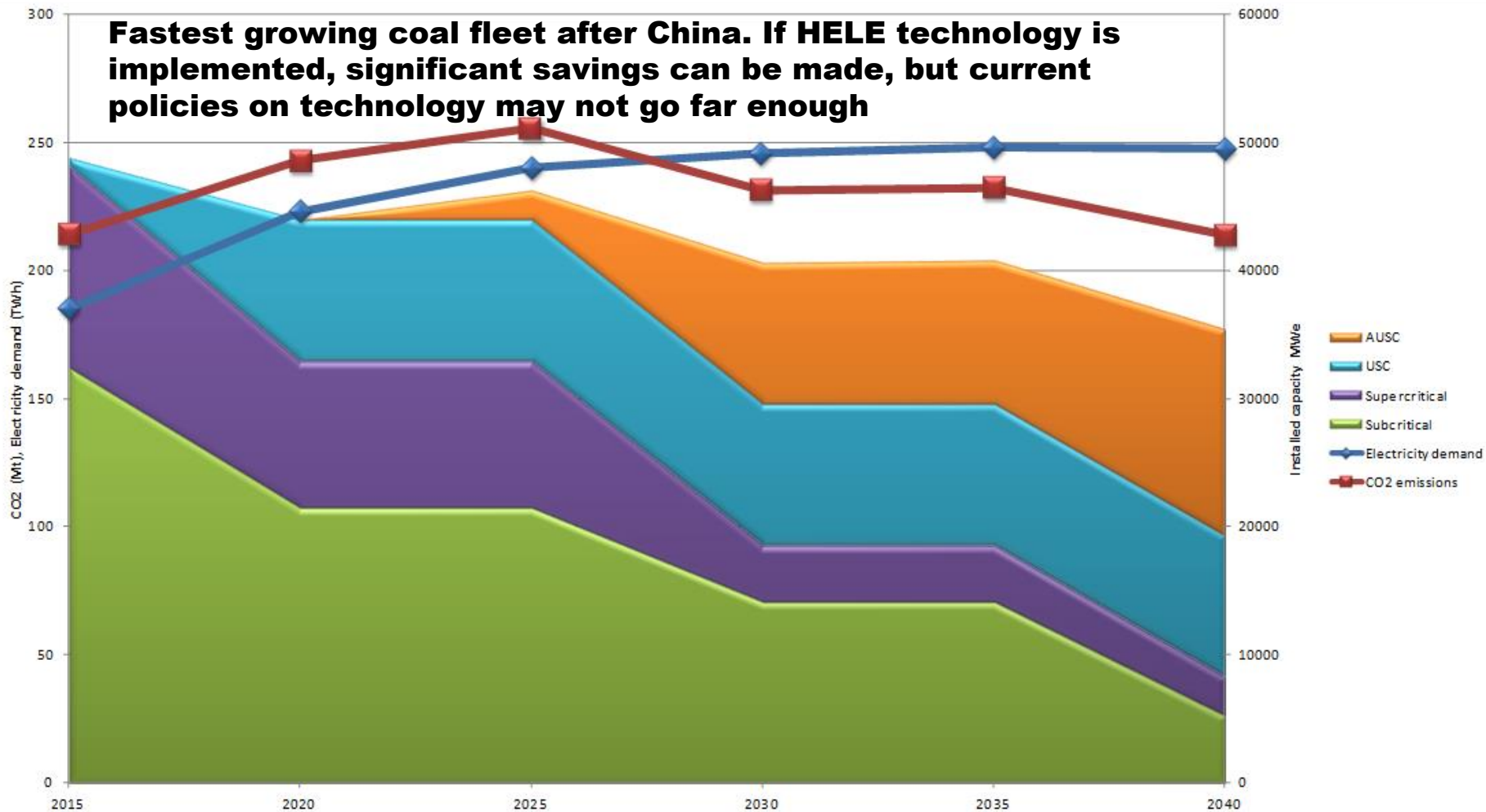

Japan – 25 year retirement scenario 2015 - 2040

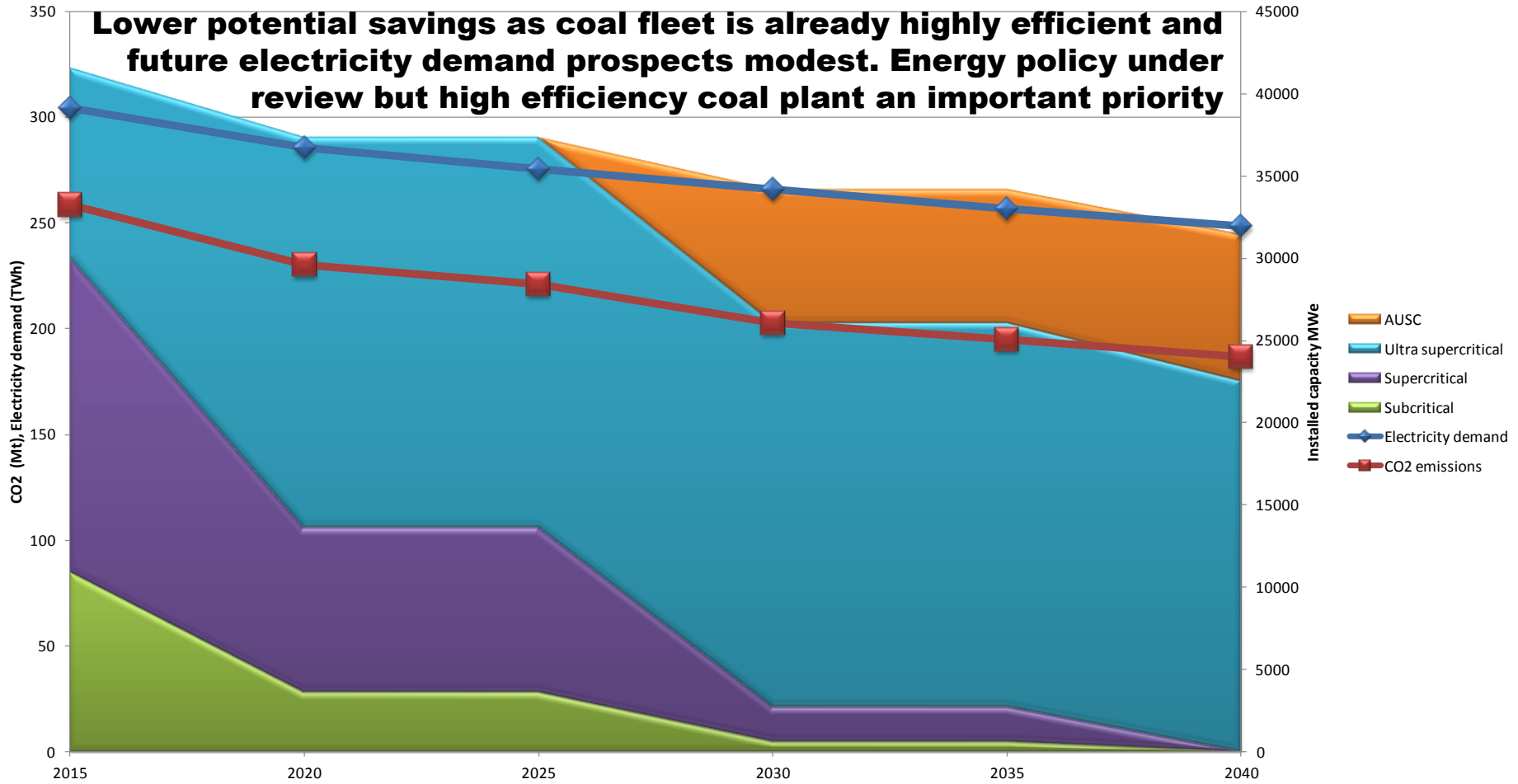

Poland – 25 year retirement scenario 2015 - 2040

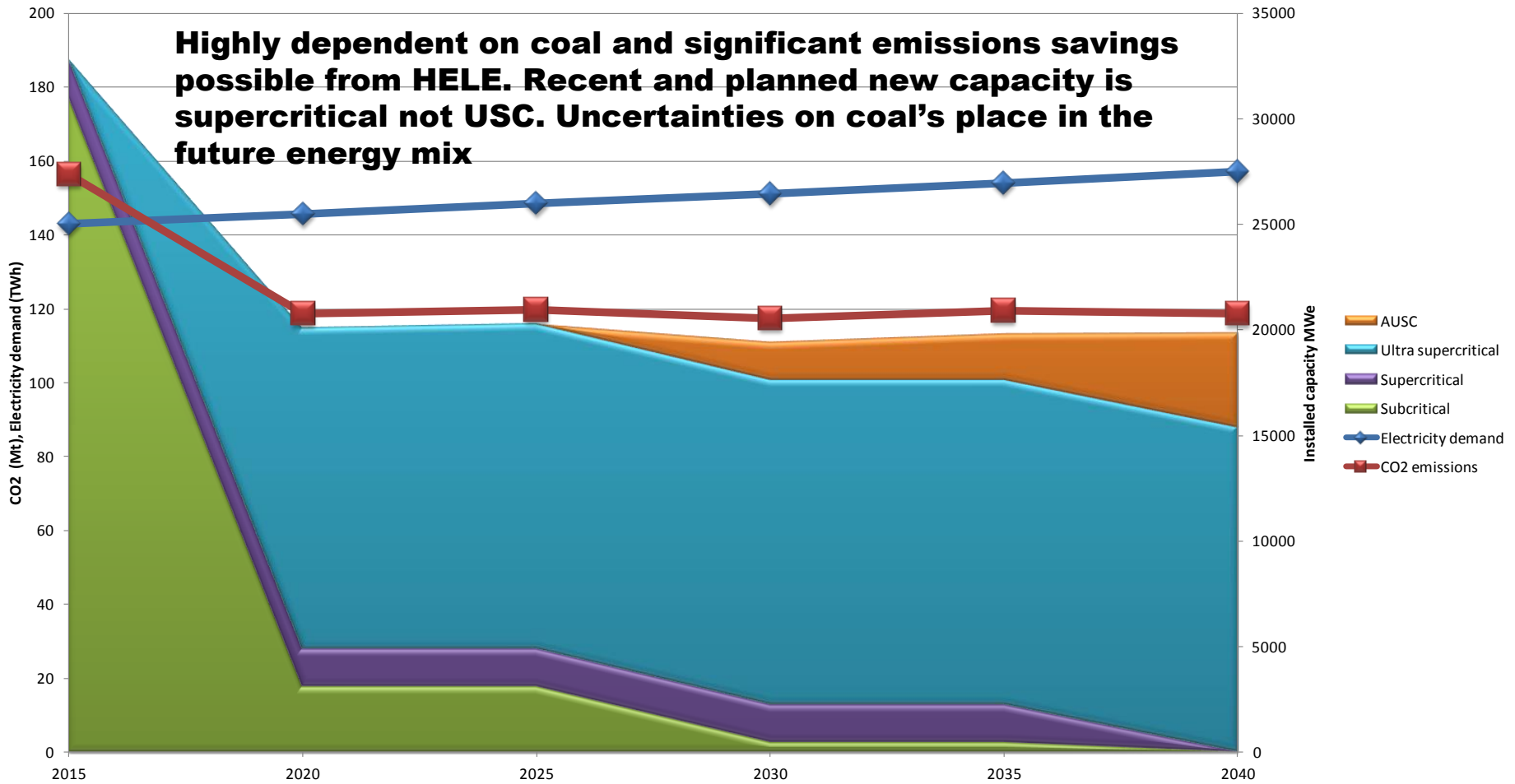

Russia – 25 year retirement scenario 2015 - 2040

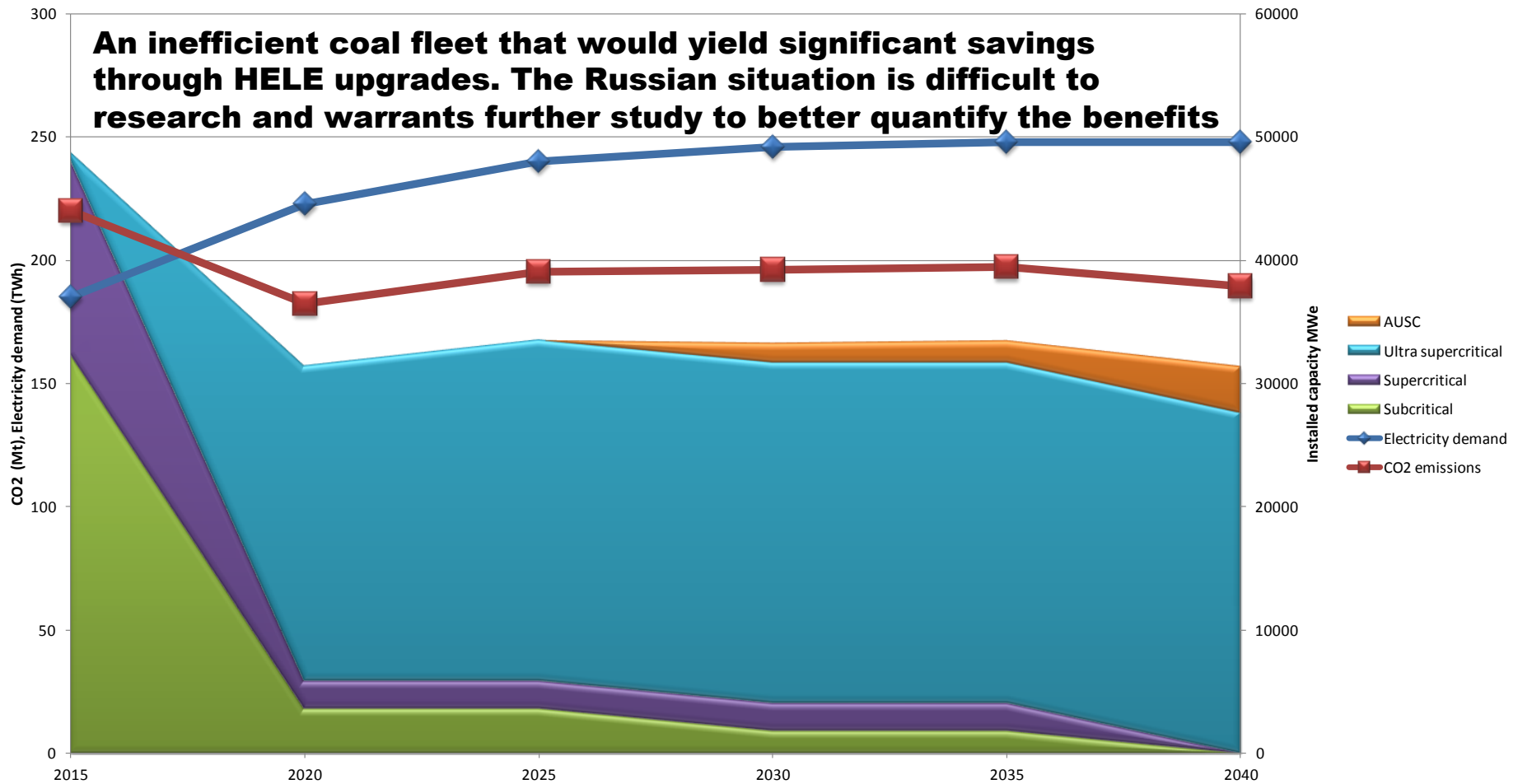

IEACCC intended further research

- **This study has provided a valuable insight into country-specific HELE possibilities but deeper analysis for all countries is recommended.**
- **Priority areas for further study are considered to be: India, South Africa, Poland and Russia.**
- **Other coal users need to be researched to complete the world view. A further overview study on HELE prospects is recommended for the “Asian Tiger” economies as a first step.**
- **Plant improvements are significant to achieving efficiency gains and a review of the current best practices is recommended leading to knowledge transfer opportunities.**

Dissemination and outreach

- **IEACCC information is available to all its members and, in due course, non-members**
- **Webinars are given on key studies, which include the HELE assessment work; all can be accessed via our website**
- **The Centre is keen to meet with potential stakeholders to discuss the work and to consider specific issues**
- **You can reach us via www.iea-coal.org**

WELCOME

THE UNITED STATES ENERGY ASSOCIATION

7TH ANNUAL
ENERGY SUPPLY FORUM

National Press Club
Washington, DC

